

PROJECT

Clogherchor Wind Farm
 110kV Grid Connection

CLIENT

FuturaEnergy Ireland

Orsted

CONSULTANTS

TOBIN
 CONSULTING ENGINEERS

NOTES: -

See General Notes

LEGEND: -

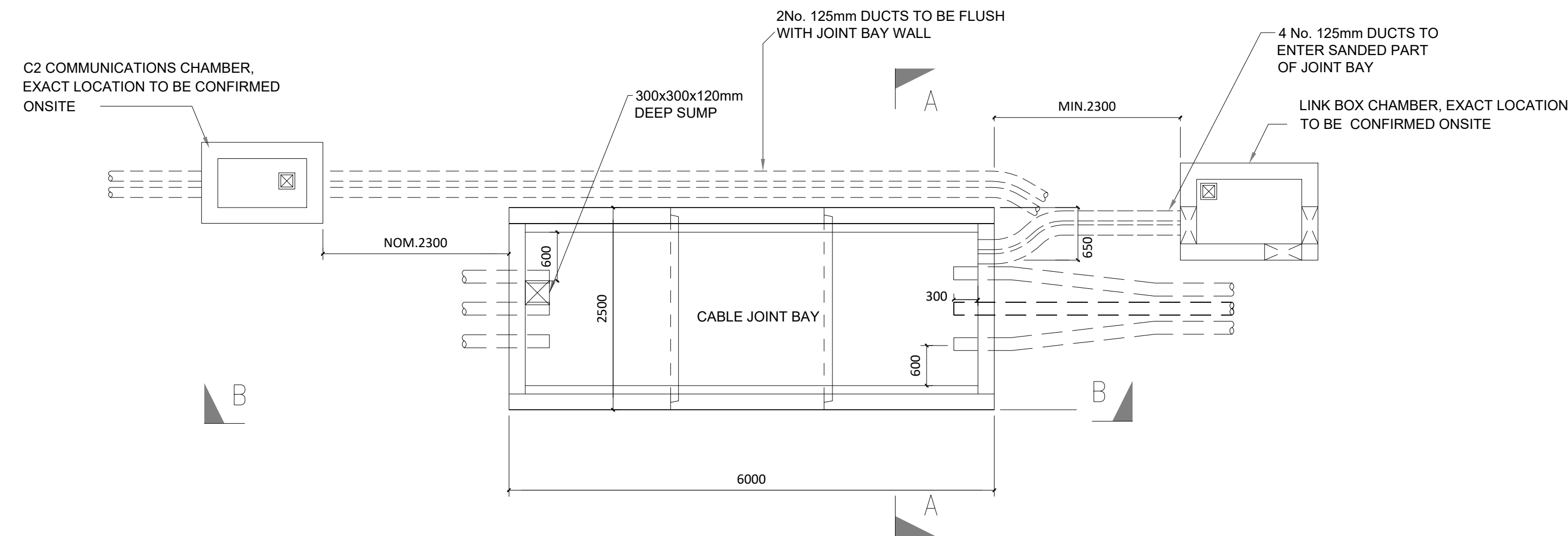

PLAN VIEW
 SCALE 1:50

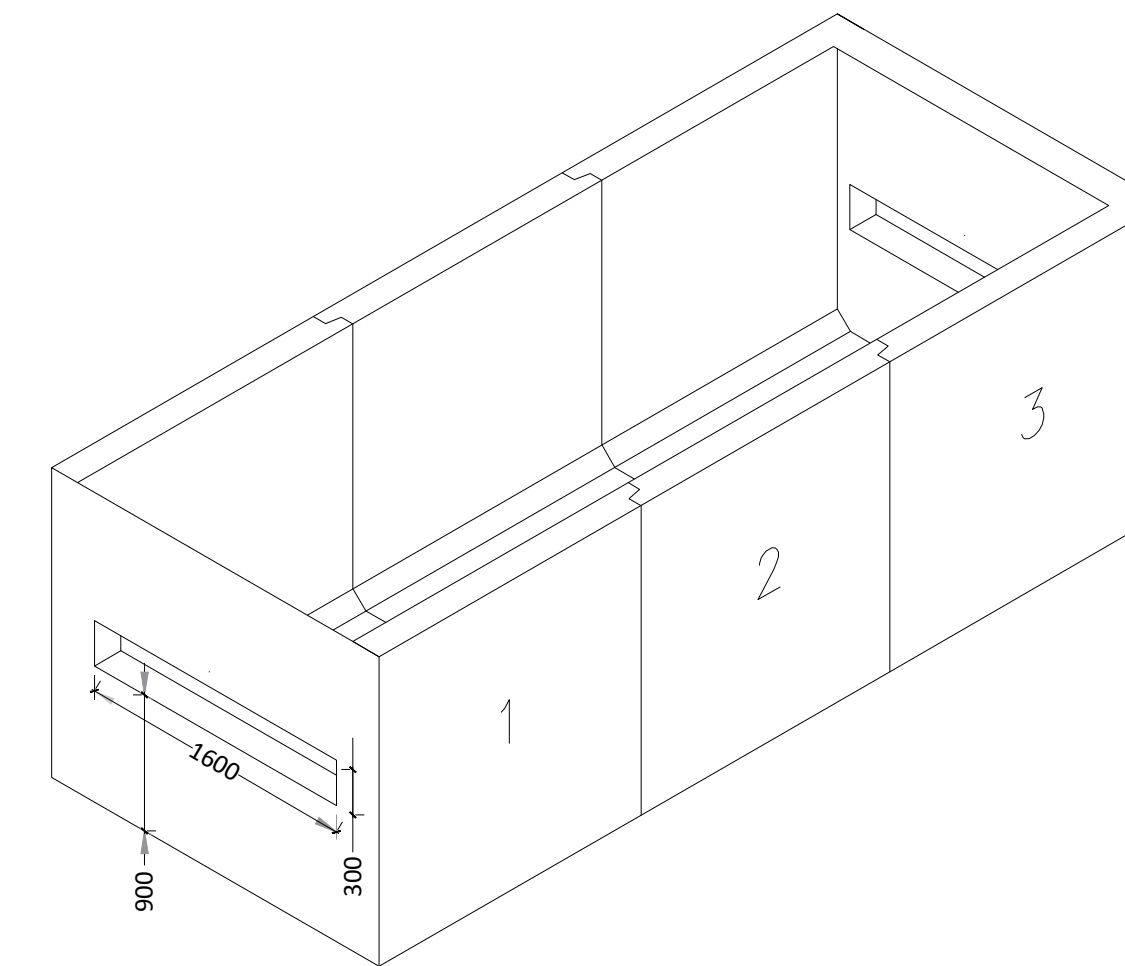

ISOMETRIC VIEW PRECAST CHAMBER
 SCALE 1:50

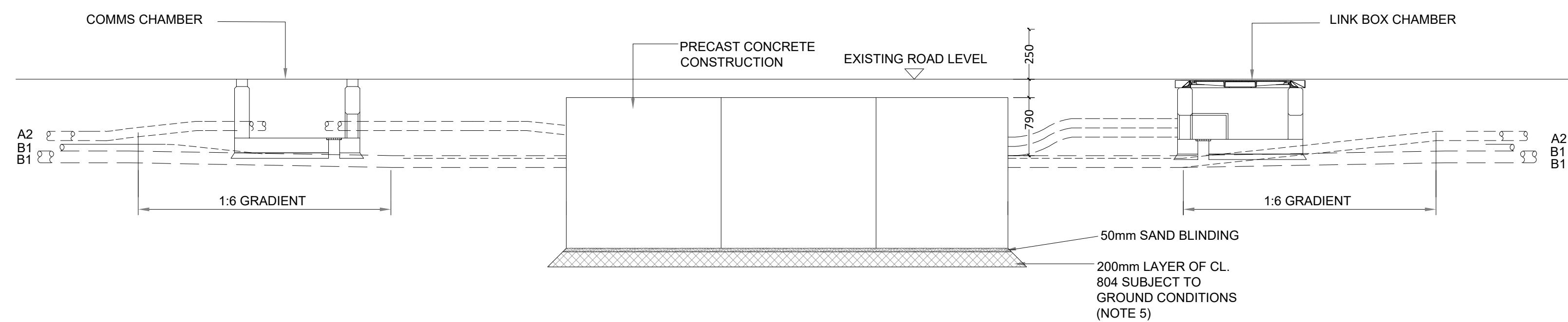

SECTION B-B
 SCALE 1:50

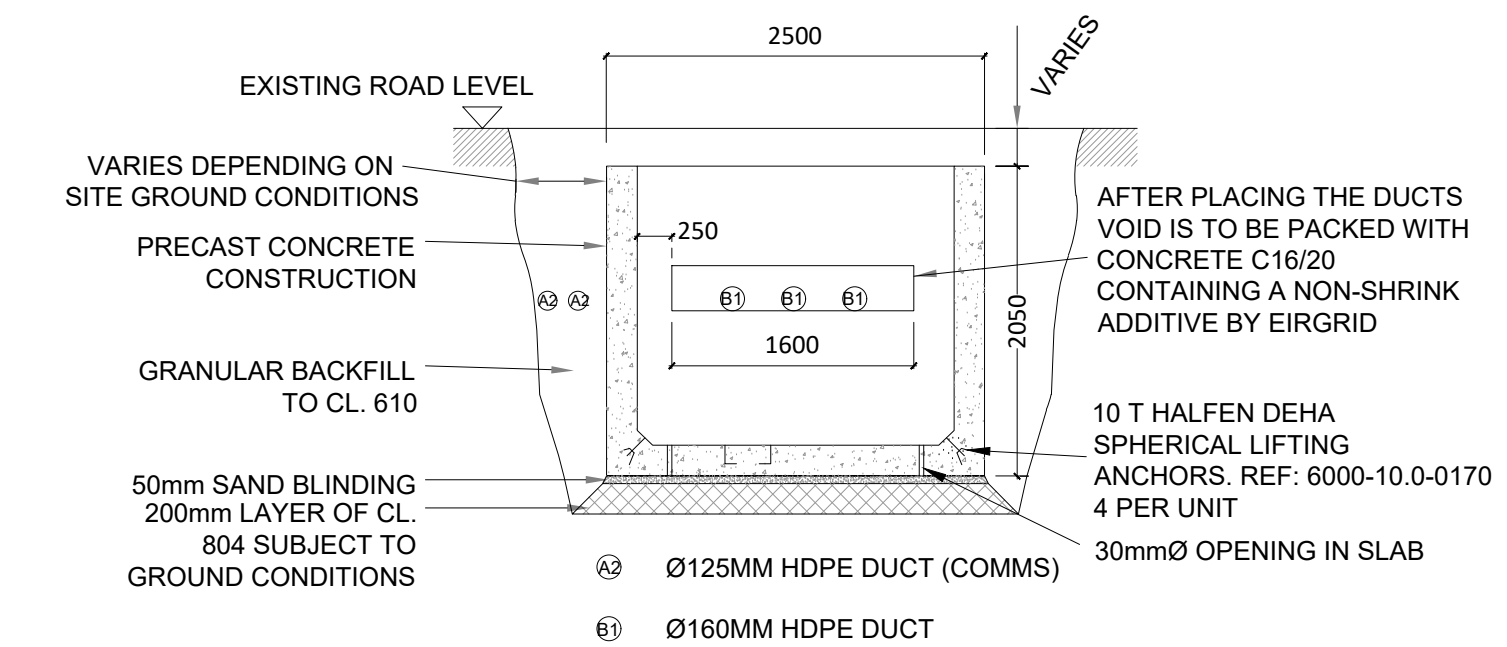

SECTION A-A
 SCALE 1:50

GENERAL NOTES:

- THIS DRAWING IS TO BE USED ONLY FOR THE PURPOSE OF ISSUE AND IS SUBJECT TO AMENDMENT.
- THIS DRAWING IS TO BE READ IN CONJUNCTION WITH ALL OTHER RELEVANT INFORMATION DO NOT SCALE FROM THIS DRAWING. USE ONLY PRINTED DIMENSIONS.
- DO NOT SCALE FROM THIS DRAWING. USE ONLY PRINTED DIMENSIONS.
- ALL DIMENSIONS ARE IN MILLIMETRES UNLESS DEFINED OTHERWISE.
- STANDARD FOUNDATIONS ARE BASED ON THE FORMATION AT THE BASE OF THE EXCAVATION SHOWN BEING SUITABLE FOR A MINIMUM BEARING PRESSURE OF 100kN/m². SUITABILITY OF STANDARD JOINT BAY FOUNDATIONS CAN ONLY BE CONFIRMED FOLLOWING GROUND INVESTIGATION. HAND VANE TESTS SHALL BE REQUIRED AS PER GI SPECIFICATION. WHERE SPECIFIED MINIMUM BEARING PRESSURE IS NOT ACHIEVABLE, AND WHERE PEAT IS ENCOUNTERED, THE CONTRACTOR SHALL REFER TO THE ENGINEER FOR GUIDANCE.
- THE LENGTH OF BONDING LEAD LENGTH SHALL IN NO CASE EXCEED 10M. NO JOINTS IN BONDING CABLE ARE PERMITTED.
- ALL EARTHING SHALL BE IN ACCORDANCE WITH ENA ER C55 AND EIRGRID/ESBN FUNCTIONAL SPECIFICATION
- THE DEPTH FROM GROUND/ROAD LEVEL TO THE TOP OF THE CONCRETE WALL SHALL BE
 - 500MM - IN CULTIVATED FIELDS & GRASS LAND
 - 300MM - IN PAVED ROADS AND GRASS VERGES
 - 350MM - IN PAVED CITY ROADS AND GRASS VERGES
- LINK BOX CHAMBERS TO BE POSITIONED AT THE EDGE OR OFF ROAD
- LINK BOX CHAMBERS AND C2 COMM CHAMBERS FINAL POSITIONING TO BE AGREED WITH EIRGRID PRIOR TO INSTALLATION

ISSUE/REVISION

NO	DATE	DESCRIPTION
P01	11.01.23	Issued for Information
P00	03.10.22	Issued for Information
I/R	DATE	DESCRIPTION

PROJECT NUMBER

05-725

SHEET TITLE

110kV Joint Bay General Arrangement and Details

SHEET NUMBER

05725-DR-128