

PARALLEL GROOVE CLAMP	
ITEM	CODE
95CU	1183031
200ACSR	1183036
300ACSR	1183035

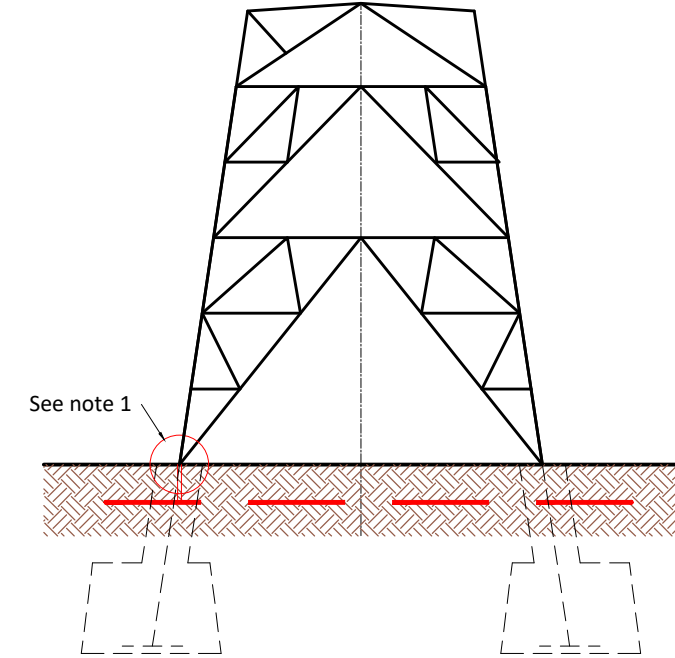

EARTH RING DETAILS - NTS

NOTES:

- 1: Earth Ring bolt fixed to 1493ET L/C Mast by Radial Electrode at Left Mast Leg - Longitudinal Face and Right Mast Leg - Transversal Face . (indicated by circle). For details of the earth connection points please refer to manufacturers specification. Overground earth connection insulated.
- 2: Earth system consists of Radial Electrode (Potential Control Ring -95mm<sup>2</sup> Cu/200/300ACSR) laid into trench.
- 3: Parallel Groove Clamps. If using 95mm<sup>2</sup> Cu copper Electrode, copper inserts required between clamp and electrode.

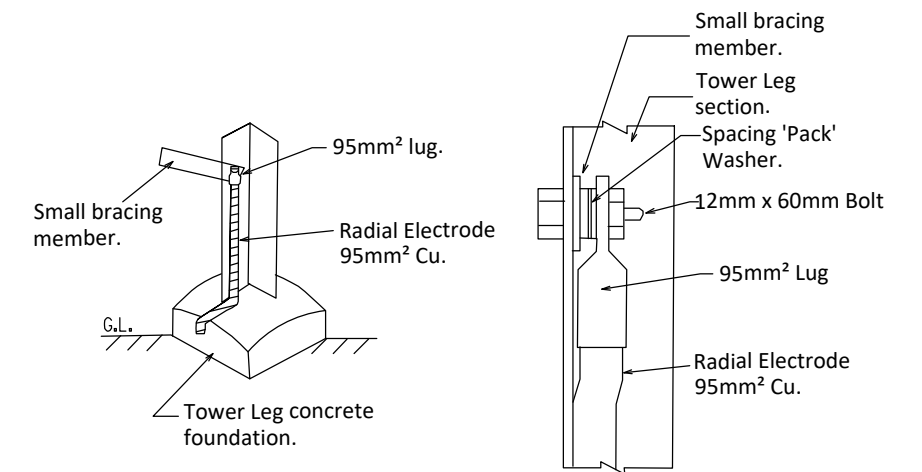
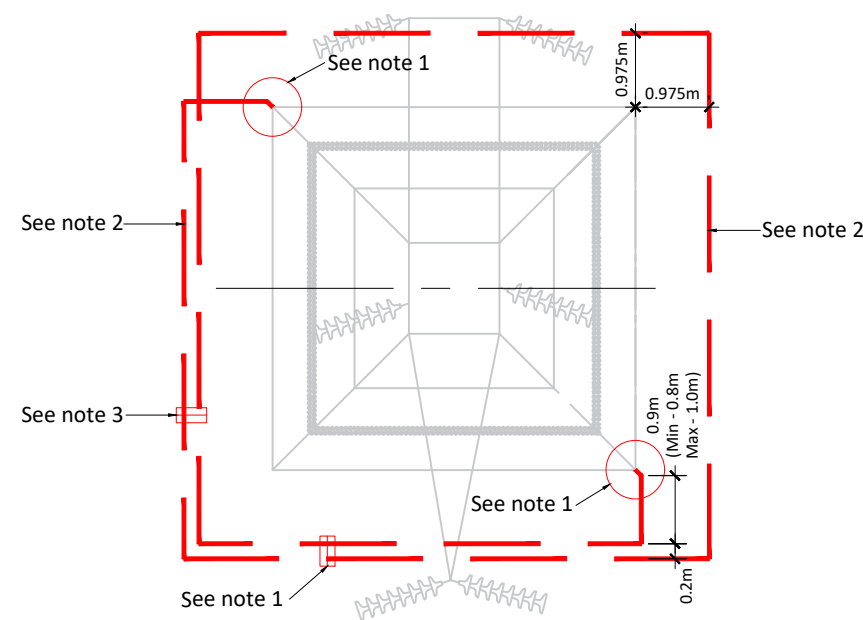

Head Office  
 Beenreigh,  
 Abbeydorney,  
 Tralee, Co. Kerry  
 Ireland  
 Tel: 00353 66 7135710



PROJECT  
 Clogherchor Wind Farm  
 110kV Grid Connection

PROJECT NUMBER  
 05-725

SHEET NUMBER  
 05725-DR-109

SHEET TITLE  
 Type 1493ET L/C Tower  
 Earth Ring Details

DRAWING STATUS  
 For Information

ISSUE/REVISION		
I/R	DATE	DESCRIPTION
P01	11.01.23	Issued for Information
P00	30.09.22	Issued for Information